

V1970 HOOK AND PLATE FASTENER

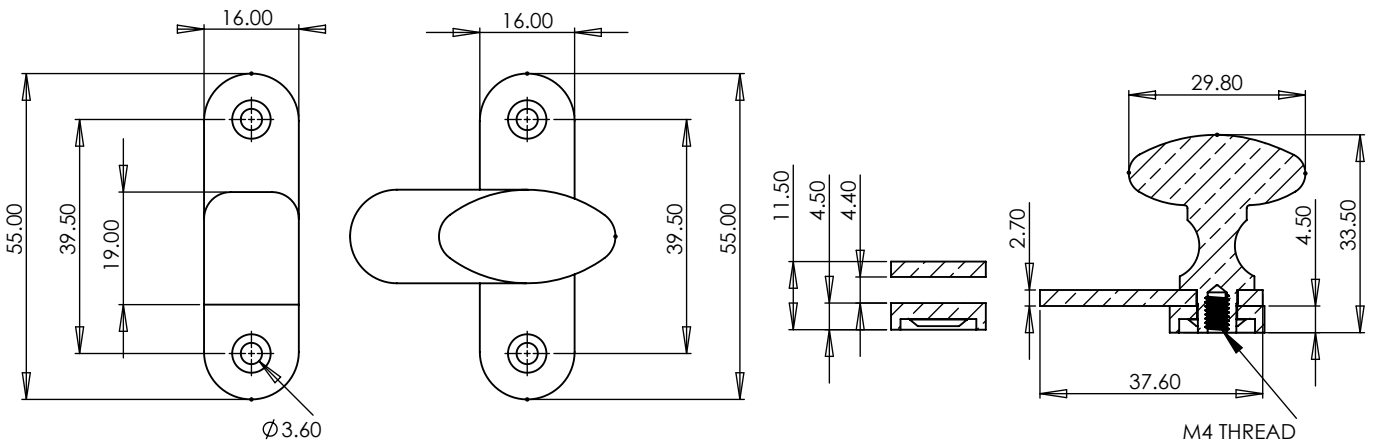

2

1



2 Dimensions: see the outlines given above

3 Starter screw x 1pc.
Drill pilot holes, use the starter screw to cut a thread

4x Brass wood screws
Fasten the brass screw into the pilot hole

FINISHES

- ME Matt Bronze finish
- SB Satin Brass finish
- PN Polished Nickel finish
- SN Satin Nickel finish
- AT Antique Brass finish
- SR Satin Rose Gold finish
- SC Satin Chrome finish
- PE Polished Brass finish
- PC Polished Chrome finish
- BK Matt Black finish

Overview

1 Hook and Plate Fastener illustrated

2 General Dimension of Hook and Plate Fastener

3 Supplied with:
4x Brass wood screws
1x Starter screw

M Marcus Ltd., Dudley

Product Code

V1970

Material

Solid Brass

Sizes shown are in mm and approximate. We reserve the right to amend where necessary and without any prior notice.