

CE MARKED TUBULAR LATCH 3"~ Bolt Through

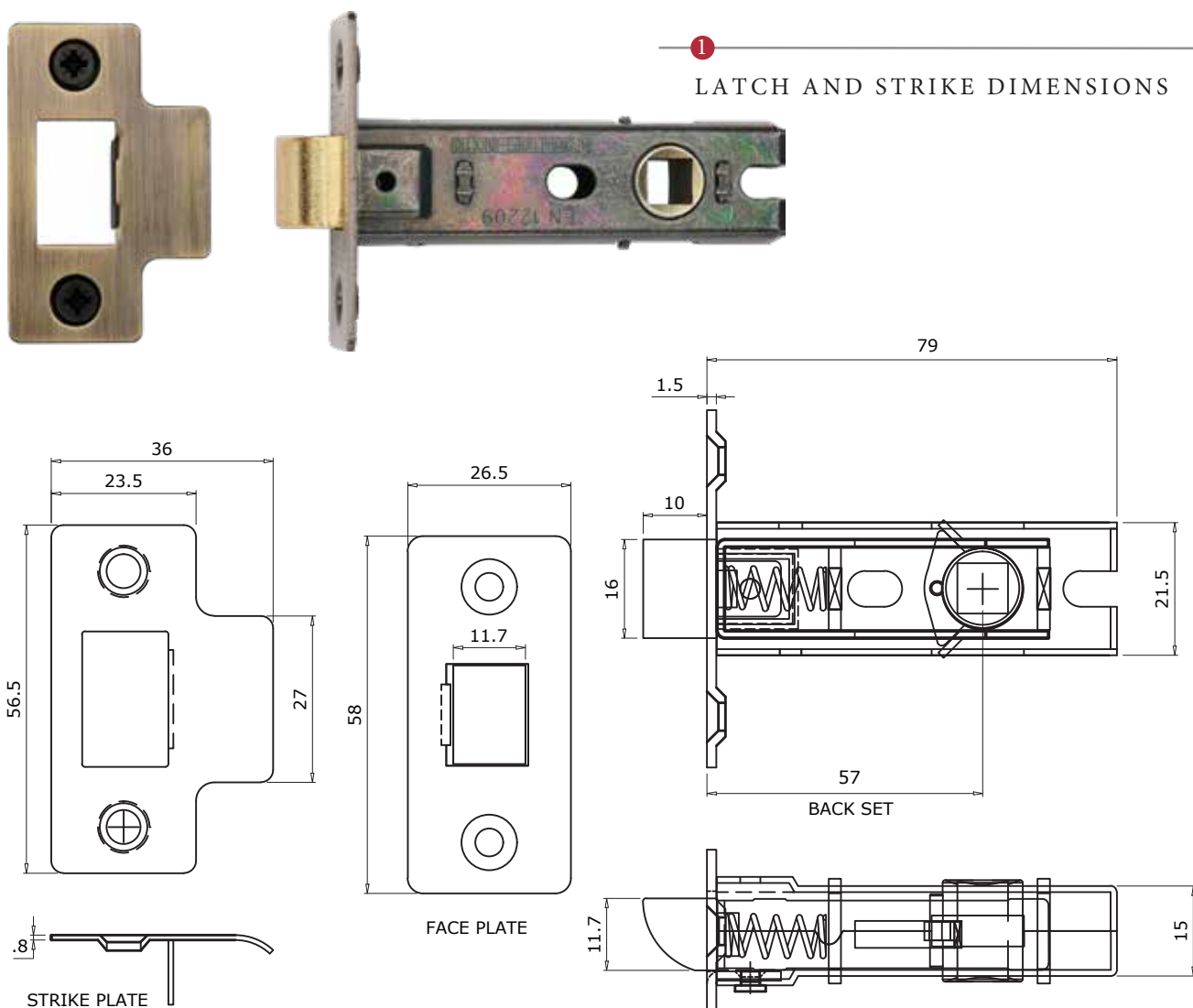

1 LATCH AND STRIKE DIMENSIONS

SIZES CODES & FINISHES

CE TUBULAR LATCH



LAL0082-AT	3" Antique Finish
LAL0082-BLK	3" Black Finish
LAL0082-MB	3" Matt Bronze Finish
LAL0082-PB	3" Brass Finish
LAL0082-PC&PN	3" Pol.Chrome/Nickel Finish
LAL0082-SB	3" Satin Brass Finish
LAL0082-SN&SC	3" Satin Chrome/Nickel Finish

- CE Tubular Lightly Sprung Latch
- CE Marked / UKCA Marked.
- Fire tested to BS EN 1634-1 suitable for use on 30 minute and 60 minute FD30 and FD60 fire doors.
- Tested to BS EN 12209-2003 the standard for mechanical locks and latches.
- Follower is suitable for 8mm square spindle
- Suitable for bolt through fixing 32-38mm
- To be used with Sprung furniture
- Suitable for use on standard & fire doors
- 2 1/2" recommended for Levers
- 3" recommended for sprung Mortice Knobs
- (Not recommended for unsprung Mortice Knobs)

Box Contains

1 Tubular Latch and Strike plate(s)

2 4x screws

3 Dust box

M Marcus Ltd., Dudley

Material	Product Code	Description	Sizes shown are in mm and approximate. We reserve the right to amend where necessary and without any prior notice.
Metals	LAL0082	CE Tubular Latch ~ Bolt Through	